

LXM Container

Description

Intermodal ISO stainless steel 20ft tank container. UN T11

Overall Length	6058mm	Tare	3,290 kg
Overall width	2438 mm	Load	32,710 kg
Overall height	2591 mm	Gross	36,000 kg
		Volume	21,000 L

Intermodal – may be carried by truck or on rail and transferred empty or fully laden.
 Standard ISO 2.6m container and corners.
 Handling – toplift or swinglift only (no forklift).
 Stacking – stack up to 3 high fully laden or empty
 Integrated CIP (clean-in-place) system.
 Automatic pressure/vacuum relief valve/filtered to EU5 standard (required for pasteurised product).
 For FOODGRADE product only (suitable for pasteurised product).

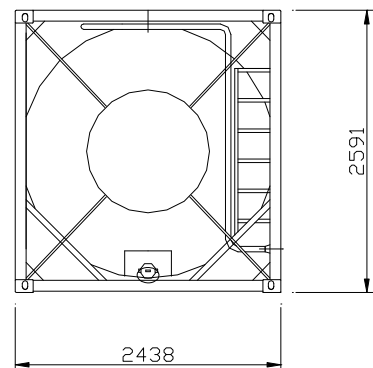
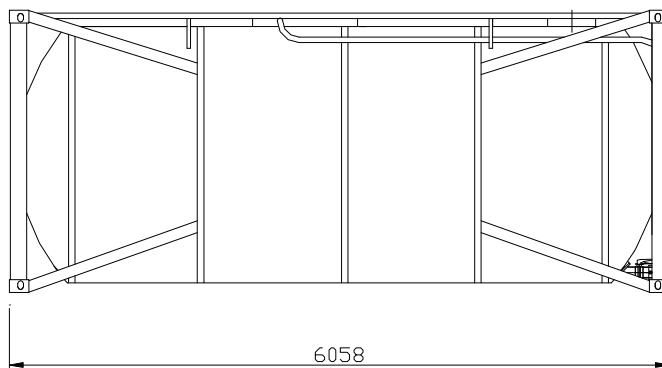
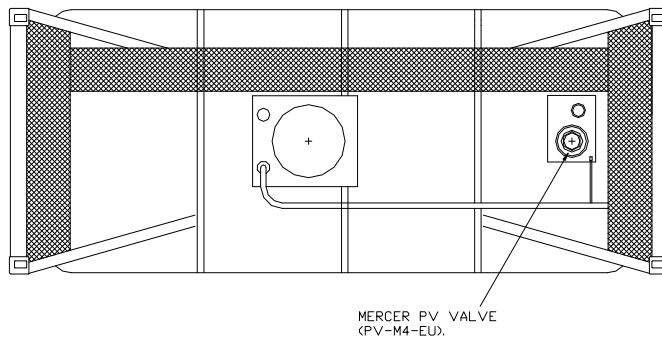

Technical Data

Diagram	LXM2
CIMC General Arrangement	15022730
Tank modifications	15023128 & 15023129
Clearance diagram	Does not exist
Stencilling diagram	15023134
Cleaning-in-place system	15023130
Spill box hose repositioning	15023133
Operating Quick Guide	M9203/56
Maintenance manual	M9200/36
Monthly Inspection Sheet	M9202/3

Notes

Leased from Cronos. Specification NTC-1753, General Arrangement NTC-1753G

Tank series numbers: LXM4019-LXM4278

Max. working pressure = 4 bar.

External pressure = 0.41 bar.

Vessel material - grade 316 stainless steel.

Manway fitted on top.

Insulation: 50mm thick rockwool/GRP cladding.

CIP system - 3 spray balls connect to internal tank-mounted boom – coupling is a 2 1/2" RJT.

Relief valve – automatic, Mercer relief valve incorporates internal CIP and two spray balls.

Mercer model PV-M4-EU (EU5 filtration standard) – no air connection is required for filling, discharge or CIP – the valve looks after itself.

Discharge coupling is a 4" Camlok male fitting.

Intended for Fonterra milk products.

25 Units converted in 2008 by Stainless Systems, Blenheim.